



一众显示科技有限公司

TEAM SOURCE DISPLAY TECH. CO, TD.

Smart Module Specification

Module NO.: TSS013004A

Version: V1.0

APPROVAL FOR SPECIFICATION

APPROVAL FOR SAMPLE

For Customer' s Acceptance:	
Approved by	Notes

TSD:		
Presented by	Reviewed by	Approved by
hcr	Aron	Aron

1 Basic information

TSS013004A is a serial communication TFT color screen display knob switch module based on the RTOS/STM32 platform. Through optimization algorithms, it achieves rapid collaboration among the main chip, display screen, and encoder switch, resulting in excellent screen refresh rate and dynamic display effect. The module adopts an integrated design, and the screen, electric control, and coding switch are integrated into one body, with excellent reliability and excellent control feel. It is suitable for various application scenarios that require button control, such as home appliances, smart homes, car central controls, beauty equipment, and industrial controls.

Communication interface	UART
MCU	STM32C091, 48 MHz, Cortex®-M0+
Display Specifications	1.3"/IPS/240*240
Memory	64Mbit norFlash(Support customize)
Operation type	Rotate and press
Ambient Light	RGB tricolor light circle at the bottom, customizable
UI content	Support customization and secondary development of TouchGFX
Appearance	Plastic chrome plated/2.0D/2.5D integrated black glass cover plate (customizable)
Expand Ports	6 GPIO
Housing color	Silver

2 Technical Information

2.1 Appearance



Picture: Appearance

2.2 Outline dimensions

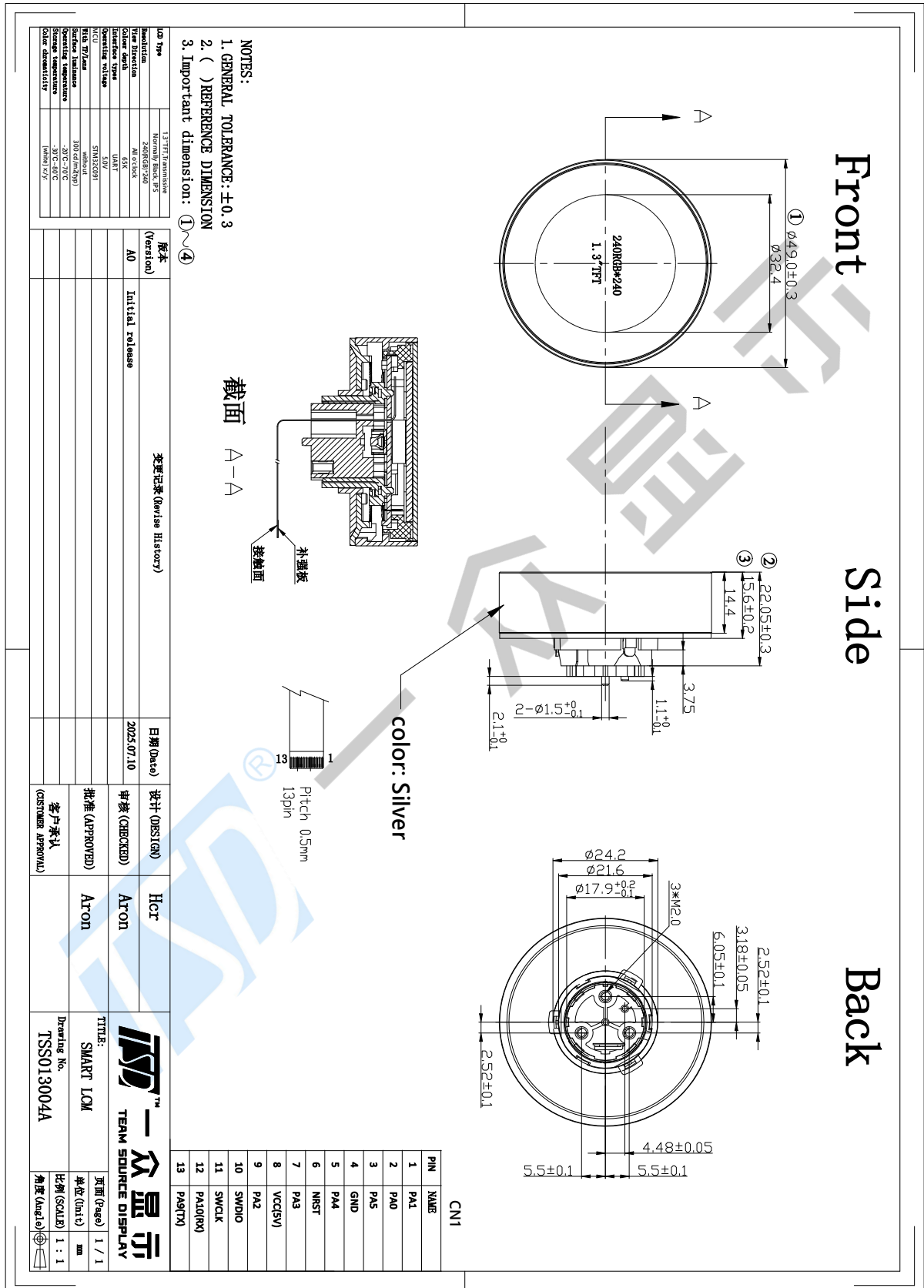

2.3 Basic structure

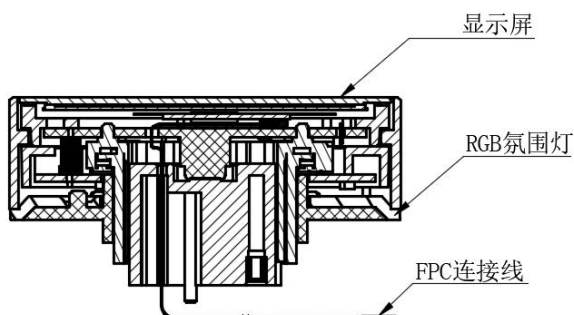

Image: Part structure

2.4 Interface Definition

No.	PIN Name	Pin type	Alternate functions
1	PA1	I/O	SPI1_SCK/I2S1_CK, USART2_RTS/USART2_DE/USART2_CK, TIM17_CH1, TIM2_CH2, USART1_RX, TIM1_CH2, I2C1_SMBA, EVENTOUT, TIM15_CH1N, USART4_RX
2	PA0	I/O	SPI2_SCK, USART2_CTS/USART2_NSS, TIM16_CH1, TIM2_ETR/TIM2_CH1, USART1_TX, TIM1_CH1, USART4_TX
3	PA5	I/O	SPI1_SCK/I2S1_CK, USART2_RX, TIM1_CH3N, TIM2_ETR/TIM2_CH1, USART3_TX, TIM1_CH1, EVENTOUT
4	GND	Ground	
5	PA4	I/O	SPI1_NSS/I2S1_WS, USART2_TX, TIM1_CH2N, SPI2_MOSI, TIM14_CH1, TIM17_CH1N, EVENTOUT
6	NRST	I	System reset pin, active low.
7	PA3	I/O	SPI2_MISO, USART2_RX, TIM1_CH1N, TIM2_CH4, TIM1_CH4, EVENTOUT, TIM15_CH2
8	VCC	Power	4.5~5.2V , 5V/80mA(type)
9	PA2	I/O	SPI1_MOSI/I2S1_SD, USART2_TX, TIM16_CH1N, TIM3_ETR, TIM1_CH3, TIM2_CH3, TIM15_CH1
10	PA13	I/O	SWDIO(default),
11	PA14	I/O	SWCLK(default), BOOT0
12	PA10	I/O	USART1_RX(default), SPI2_MOSI, TIM1_CH3, MCO2, TIM17_BKIN, I2C1_SDA, EVENTOUT, I2C2_SDA
13	PA9	I/O	USART1_TX(default), TIM1_CH2, TIM3_ETR, SPI2_MISO, TIM15_BKIN, I2C1_SCL, EVENTOUT, I2C2_SCL

2.5 Technical parameters

2.5.1 Basic parameters

Performance parameter	Technical requirement	Remarks
Operating voltage	4.5V~5.5V, Typical : 5V	
Operating current	50mA~150mA, Typical 80mA	
Display Color	65K	
Display resolution	240 (W) *3(RGB)240 (H)	
Display Brightness	300±10%cd/m ²	
Viewing angle	ALL	
Operating temperature	-20°C~70°C/96H	
Storage temperature	-30°C~80°C/96H	

2.5.1 光学特性

Parameter 参数	Symbol 符号	Condition 条件	Min. 最小值	Typ. 典型值	Max. 最大值	Unit 单位	Remark 备注
Contrast Ratio	C/R	$\theta = 0^\circ$	900	1100	-	-	Note(4)
NTSC Ratio	S	$\theta = 0^\circ$	55	60	-	%	Note(7)
Luminance	L	$\theta = 0^\circ$	270	300	-	cd/m ²	Note(5)
Luminance uniformity	U _w	$\theta = 0^\circ$	70	80	-	%	Note(3)
Response Time	T _R + T _F	25 °C	-	30	40	ms	Note(2)
Color Coordination	W _X	$\theta = 0^\circ$ (Center) Normal viewing angle B/L On	-0.03	0.29	+0.03	NTSC (x,y)	Note(6)
	W _Y			0.32			
	R _X			0.644			
	R _Y			0.332			
	G _X			0.323			
	G _Y			0.565			
	B _X			0.134			
	B _Y			0.124			
Viewing Angle	θ_L	C/R>10	80	85	-	Degree	Note(1)
	θ_R		80	85	-		
	θ_U		80	85	-		
	θ_D		80	85	-		

Test Conditions:

1. VDD=3.3V, IF=20mA (Backlight current), the ambient temperature is +25°C.
2. The test systems refer to Note 8.

Note1: Definition of Viewing Angle: The viewing angle range that the CR>10

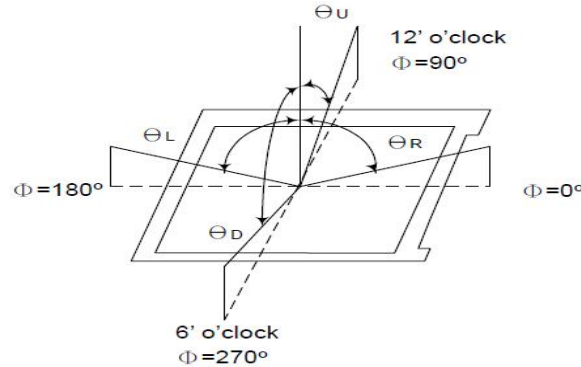

Note2: Definition of Response time: Sum of TR and TF

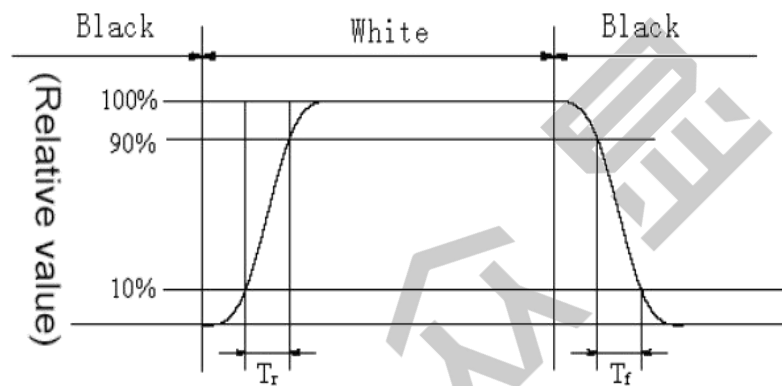

Note 3: Definition of Luminance Uniformity: Active area is divided into 9 measuring areas, every measuring point is placed at the center of each measuring area.

$$\text{Luminance Uniformity} = \frac{\text{Min Luminance of white among 9-points}}{\text{Max Luminance of white among 9-points}} \times 100\%$$

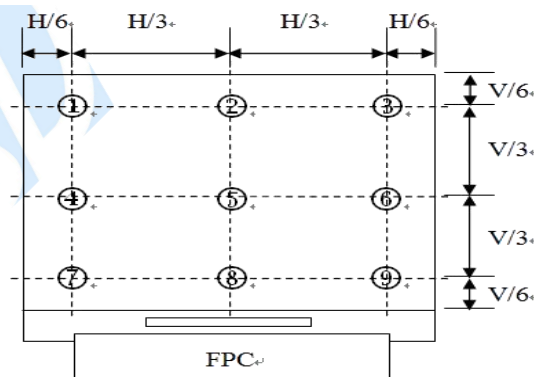

Note4: Definition of Contrast Ratio (CR): measured at the center point of panel

$$\text{Contrast ratio (CR)} = \frac{\text{Luminance measured when LCD on the "White" state}}{\text{Luminance measured when LCD on the "Black" state}}$$

Note 5: Definition of Luminance: Center Luminance of white is defined as luminance values of 1point average across the LCD surface.

Note 6: Definition of Color Chromaticity (CIE 1931)

Color coordinates of white & red, green, blue measured at center point of LCD.

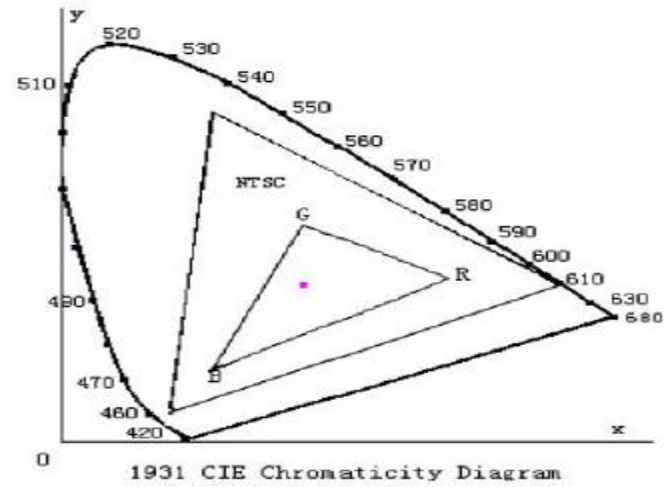

Note 7: Definition of NTSC ratio:

$$\text{NTSC ratio} = \frac{\text{Area of RGB triangle}}{\text{Area of NTSC triangle}}$$

Note 8: Definition of optical measurement system.

The optical characteristics should be measured in dark room. After 5 minutes operation, the optical properties are measured at the center point of the LCD screen. (Response time is measured by Photo detector TOPCON BM-7, Field of view: 1°/Height: 500mm.)

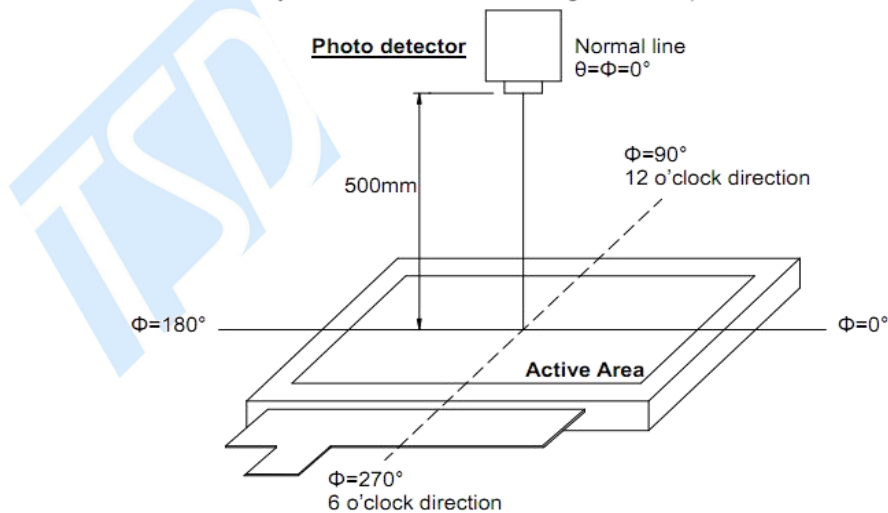

2. 6 Reliability and mechanical performance

Item 项目	Test Condition 测试条件	SPECIFICATIONS规格
Insulation impedance	Apply a voltage of 250V DC between the outer button and the base for 1 minute.	The resistance between the metal outer button and the base is above 100M Ω .
Withstand voltage	Apply an AC 300V voltage between the metal outer button and the base for 1 minute.	No insulation damage allowed
Full rotation angle		360°(无止挡点)
Rotational torque		65±20mN.m (650±200gf.cm)
Number and location of positioning points		18 point positioning (spacing angle 20 ° ± 3 °)
Axial compressive strength	At the end of the shaft, apply a static load force of 5Kgf along the axis and press down for 10 seconds (the screw is fixed on the surface shell).	There is no damage to the shaft, and there is no abnormal pressing; There are no abnormalities in electrical performance
Axial tensile strength	At the end of the shaft, apply a static load force of 5Kgf along the axis and press down for 10 seconds (the screw is fixed on the surface shell).	There is no damage to the shaft, and there is no abnormal pressing; There are no abnormalities in electrical performance
Rotational lifespan	Under no load conditions, the shaft rotates at a speed of 600-800 cycles/hour for 30000 (1 cycle refers to 360 ° clockwise rotation and 360 ° counterclockwise rotation)	Torque: -50% to+10% of initial value The knob shows no abnormal adjustment when powered on.
Moisture-proof	After being placed in a constant temperature and humidity bath with a temperature of 60 ± 3 ° C and a humidity of 90~95% for 96 ± 4 hours, the test is conducted after being placed at room temperature and humidity for 1.5 hours	The surface of the outer button is free from cracks and bubbles, and the display screen is not degummed. The knob shows no abnormal adjustment when powered on.
Heat resistance	Place in a constant temperature oven at a temperature of 70 ± 3 ° C for 96 ± 4 hours, and place at room temperature and constant humidity for 1.5 hours before testing	The surface of the outer button is free from cracks and bubbles, and the display screen is not degummed. The knob shows no abnormal adjustment when powered on.

Cold resistance	阶段 step	温度 Temperature	放置时间 Duration	The surface of the outer button is free from cracks and bubbles, and the display screen is not degummed. The knob shows no abnormal adjustment when powered on.
	1	-20℃	0.5 hour	
	2	常温 standard atmospheric conditions	0.5 hour	
	3	70℃	0.5 hour	
	4	常温 standard atmospheric conditions	0.5 hour	
试验周期: 5周 test cycle: 5 cycles				
After testing according to the above conditions, place it in a normal temperature and humidity environment for 1.5 hours before testing.				
Press the switch for power	Apply an axial force to the cover plate until it remains stationary, taking the maximum value during the force application process.			500±200gf
Press the switch movement amount	Fix the product on the surface cover plate, apply a static load force of twice the acting force directly above the cover plate, and measure the movement distance of the knob when it is pressed to the point where it cannot move.			1.5±0.3 mm
Switch press life	After the product is fixed, apply 300gf of axial pressure, press to the end and release to allow it to freely reset. Press 30000 times. Press at a speed of 1500 to 1800 times per hour.			Press the -50%~+10% knob with the initial power as the driving force, and the power on display adjustment is normal. The plastic part is free from damage, deformation, and rotation is normal.

2.7 Precautions for use

Avoid storing in high temperature, damp, and corrosive areas Try to use the product within 6 months after purchase The remaining unused products after unpacking should be stored in a moisture-proof and gas proof environment.

Operating temperature range: -20 °C~70 °C, long-term high-temperature operation can lead to failure.

The static sensitive components of the main control board must come into contact with an anti-static wrist, especially the main control chip.

The DC power supply voltage during sample inspection and testing should not exceed 8V to prevent jumping, surge, breakdown or damage to the voltage regulator chip during power contact.

3 Transportation and storage

3.1 Transportation regulations

1、 During transportation, direct or indirect exposure to rain and snow, as well as mechanical damage or dampness, should be avoided to prevent damage to the packaging.

2、 During transportation or handling, heavy falls or pressure should be avoided to avoid pin damage or deformation.

3.1 Storage Environment and Conditions

1.It should be stored in a well ventilated environment with a temperature of -15 °C to+25 °C, a relative humidity of

40% -65%, and no acid, alkali, or other harmful gases around.

2. During storage and transportation, each stack height shall not exceed 5 boxes of products.

Item	Normal parameters	Limit parameter	Material Effective Status	Remarks
Temperature	25°C	85°C	No abnormalities	
Humidity	65%	95%	No abnormalities	